

SPECIFICATIONS

NPS 4x4

| | | |
|------------------------------|--|--|
| MODEL CODE | NPS81UHH-2E | |
| Drive Train | 4 x 4 | |
| ENGINE | | |
| Model | 4HL1-TC | |
| Type | 4-Cylinder In-line, 4-Cycle, Water-Cooled OHC, Turbo with Intercooler | |
| Displacement | cc | 4,778 |
| Bore x Stroke | mm | 115 x 115 |
| Maximum Output (Gross) | kW (PS)@rpm | 99.3 (135)@2,600 |
| Maximum Torque | Nm (kgm)@rpm | 372 (38)@1,600 |
| Emission Level | Euro 2 | |
| Fuel System | Common Rail Direct Injection | |
| TRANSMISSION | | |
| Model / No. of Speed | MYY-5T / 5-Speed Manual | |
| Gear Ratio | 1st | 5.315 |
| | 2nd | 3.053 |
| | 3rd | 1.655 |
| | 4th | 1.000 |
| | 5th | 0.721 |
| | Reverse | 5.068 |
| | Final | 5.571 |
| WEIGHT & CAPACITIES | | |
| Gross Vehicle Weight | kg | 5,000 |
| Curb Weight | kg | 2,875 |
| Front | kg | 1,905 |
| Rear | kg | 970 |
| Fuel Tank Capacity | l | 100 |
| AXLE | | |
| Front | Type | Single Banjo, Full Floating with Manual Lock Hub |
| Front Axle Capacity (Design) | kg | 2,800 |
| Rear | Type | Single Banjo, Full Floating |
| Rear Axle Capacity (Design) | kg | 6,600 |
| SUSPENSION SYSTEM | | |
| Suspension | Front | Semi Elliptical Alloy Steel Leaf Spring with Double Acting Telescopic Shock Absorber, Stabiliser Bar |
| | Rear | Semi Elliptical Alloy Steel Leaf Spring with Double Acting Telescopic Shock Absorber |
| TYRES & WHEELS | | |
| Tyres | 8.5R17.5 | |
| Wheels | 17.5 x 6.00-127 | |
| BRAKES | | |
| Service | Drum Brakes with Dual Circuit Hydraulic Control, Vacuum Assistance and Load Sensing Proportioning Valve (LSPV) | |
| Parking Brake Type | Transmission Mounted, Mechanical Operated Internal Expanding | |
| Auxiliary | Exhaust Brake | |
| STEERING | | |
| Steering System | Power Assist, Recirculating Ball Type | |
| Min. Turning Radius | m | 6.6 |
| ELECTRICAL | | |
| Battery | 12V x 2 | |
| Alternator | 24V-80A | |
| DIMENSION | | |
| Overall Length | OAL mm | 5,985 |
| Overall Width | OAW mm | 2,125 |
| Overall Height | OAH mm | 2,450 |
| Wheelbase | WB mm | 3,395 |
| Front Overhang | FOH mm | 1,080 |
| Rear Overhang | ROH mm | 1,510 |
| Front Tread | AW mm | 1,675 |
| Rear Tread | CW mm | 1,650 |

ISUZU

ELF

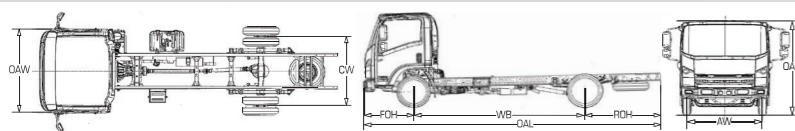

Isuzu Malaysia Sdn. Bhd. is engaged in an ongoing research and development programme, and reserves the right to change specifications, resulting in advancements or technical refinements, without prior notice. All product specifications are within normal manufacturing allowances and tolerances.

Dealer's information

ISUZU

ISUZU MALAYSIA SDN BHD (664946-H)
501D, LEVEL 5, TOWER D, UPTOWN 5, NO.5, JALAN SS21/39,
DAMANSARA UPTOWN, 47400 PETALING JAYA, SELANGOR DARUL EHSAN.
GENERAL LINE: 03-7723 9777 FAX: 03-7723 9779
HOTLINE: 1-300-88-1133 www.isuzu.net.my

Ver.01/Oct2018/BPDCVD.JL

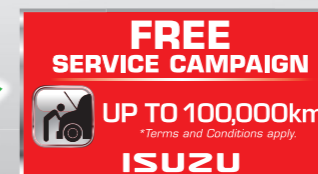

6 WHEELER 4x4

NPS
4x4
GVW 5,000kg

PERFORMANCE



NPS 4x4

4HL1-TC
HEAVY DUTY COMMONRAIL
Displacement: **4,778cc**
Max. Output (Gross): **135ps (99.3kW) @2,600rpm**
Max. Torque: **372Nm@1,600rpm**

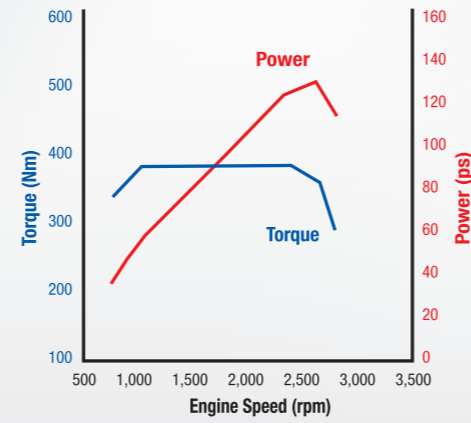

- ▲ Front free wheel hubs.
- ▲ Wider approach and departure angles.
- ▲ One piece straight chassis.
- ▲ Higher ground clearance.

EXTERIOR

- ▼ 90 Degrees door opening.
- ▼ Door visor.
- ▼ New chrome fang grille.



- ▲ Off-road tyre with wheel cap.
- ▲ Bigger axle capacity.

INTERIOR

- ▼ Ergonomic instrument panel design with ample storage compartments.
- ▼ Spacious and comfortable cabin.



- ▲ Audio and Air-cond units.
- ▲ 4x4 Switch.

SAFETY

- ▼ Energy absorbing steering wheel and column.
- ▼ Door impact beam with high tensile strength reinforcement frame.
- ▼ Rear fog lamp and reverse sensor.

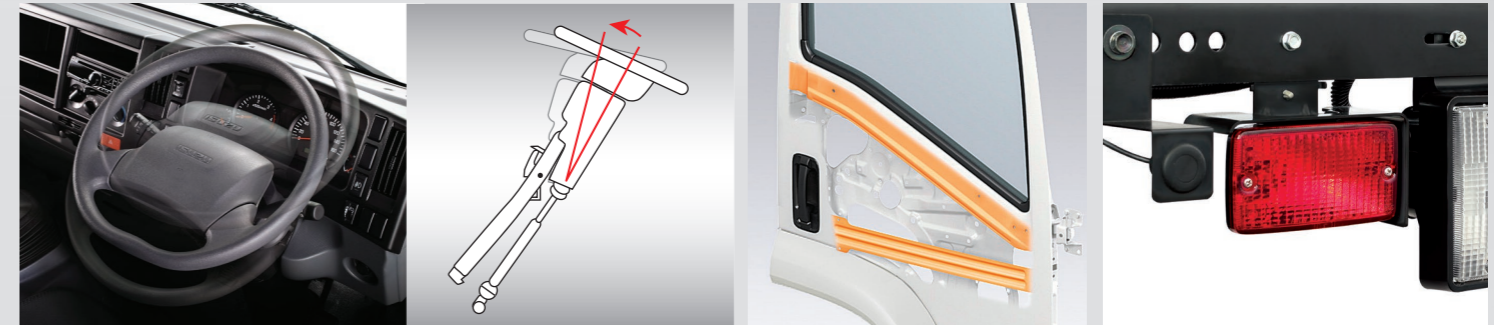

- ▲ Headlight leveling. Preferred headlight beam position can be maintained when truck is loaded and when it has no load.
- ▲ Load sensing proportioning valve (LSPV).

BODY APPLICATION

| MODEL | NPS 4x4 | |
|-------|----------|----|
| | Standard | ft |

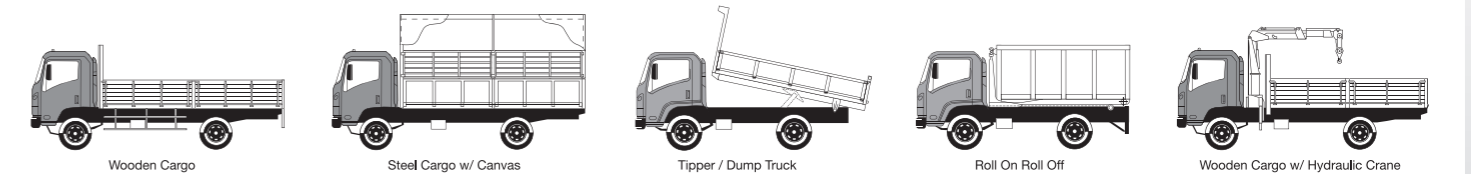

*Body length may vary according to rear body type application. Refer to ISUZU authorised drawing plan for actual body length at ISUZU dealers. Pictures shown are for illustration purposes only.